

General Setup Instructions

- Read entire setup instruction manual prior to unpacking parts and pieces.
- The setup instructions are created specifically for this configuration.
- Setup instructions are laid out sequentially in steps, including exploded views with detailed explanation for assembly.

Cleaning & Packing

- For Cleaning Metal, Plex, & Laminate Parts: Use a **MILD NON-ABRASIVE** cleanser and soft cloth/paper towel to clean all surfaces.
- Keep exhibit components away from heat and prolonged sun exposure. **Heat and UV exposure will warp and fade components.**
- Retain all provided Packing Materials. All provided packing materials are for ease of repacking & component protection.

Disassembly

- For loss prevention, tighten all set screws and locks during disassembly.

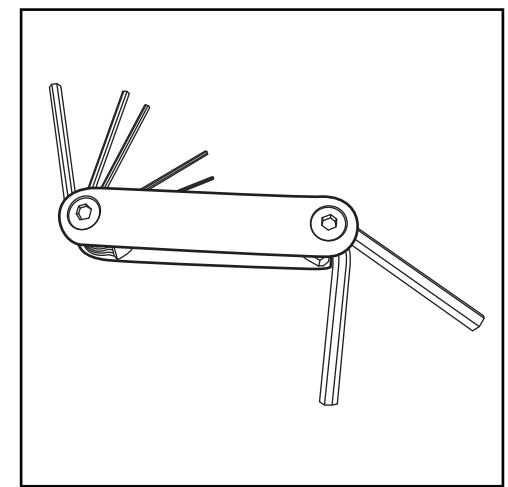

Hex Tool - Essential for Assembly

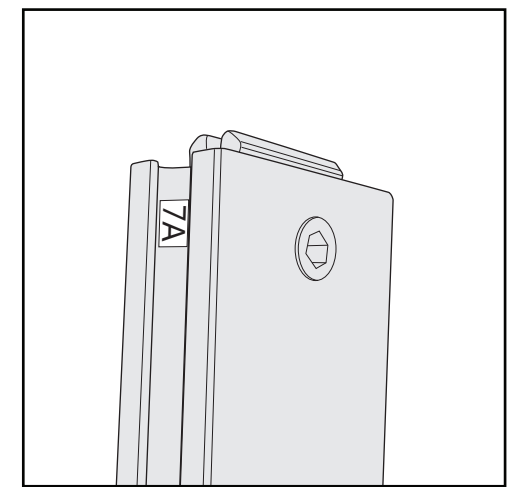

Part Identification - Numbering

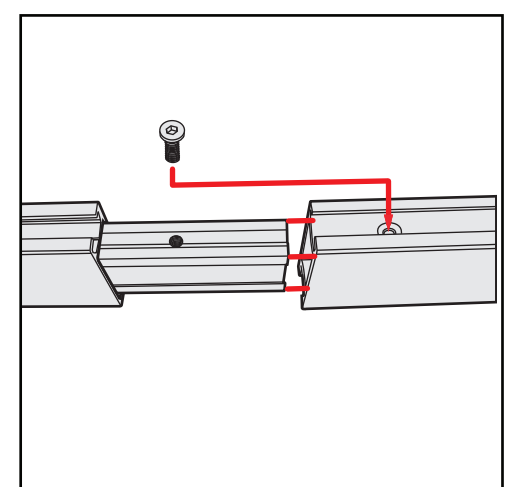

Spline Connection

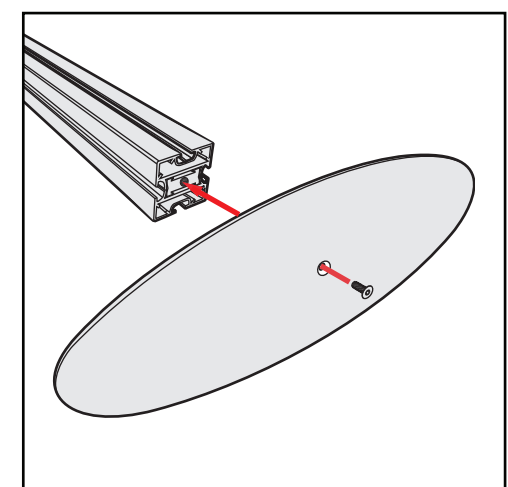

Base Plate & Extrusion Connection

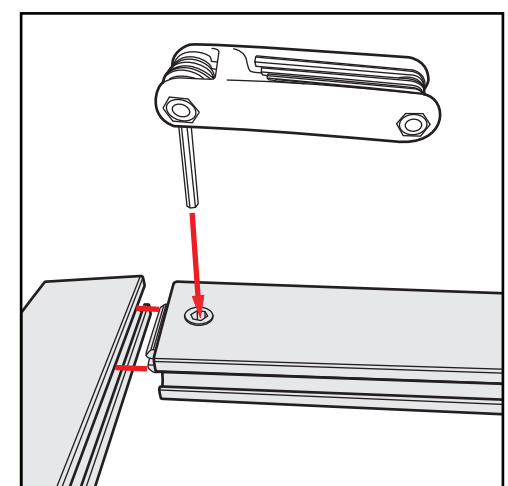

Extrusion & Lock Connection

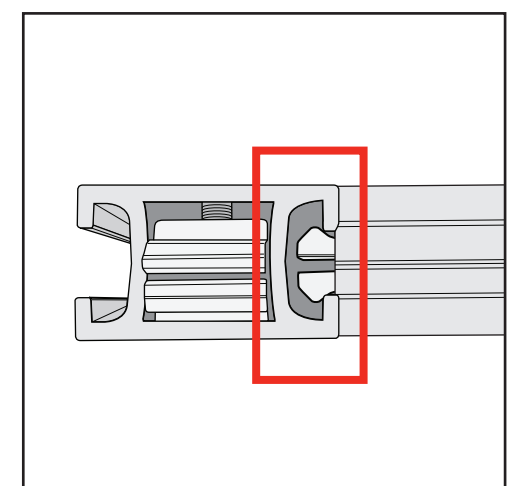

Engaged Lock

 **WARNING**

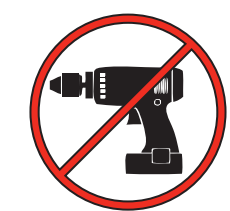

DO NOT USE POWER TOOLS

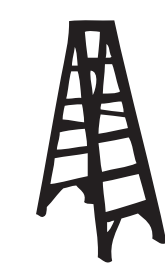

LADDERS OR LIFTS MAY BE REQUIRED



ALL CONNECTIONS MUST BE TIGHTLY SECURED

Straight Connection

When assembling frame, first attach all **straight connectors**, then attach **corner connectors**.

- 1) Place extrusions end-to-end.
- 2) Loosen all knobs, then slide **straight connectors** across the seam of extrusions.
- 3) Tighten all knobs to secure connection.

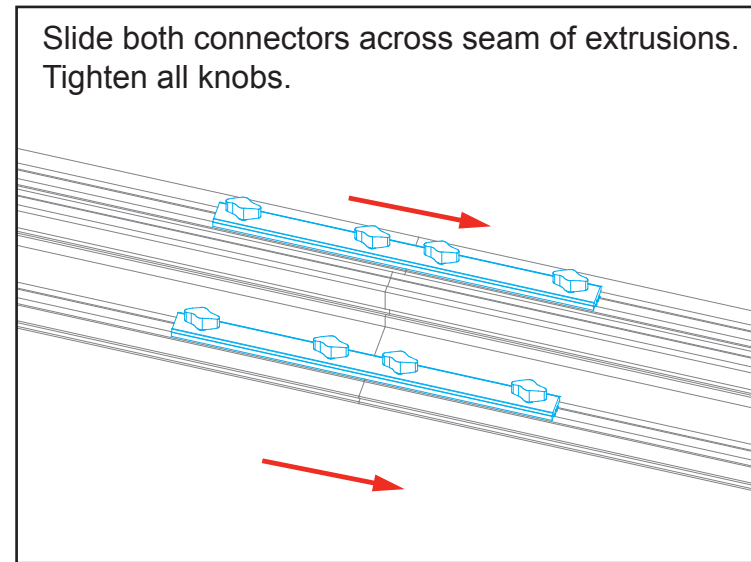
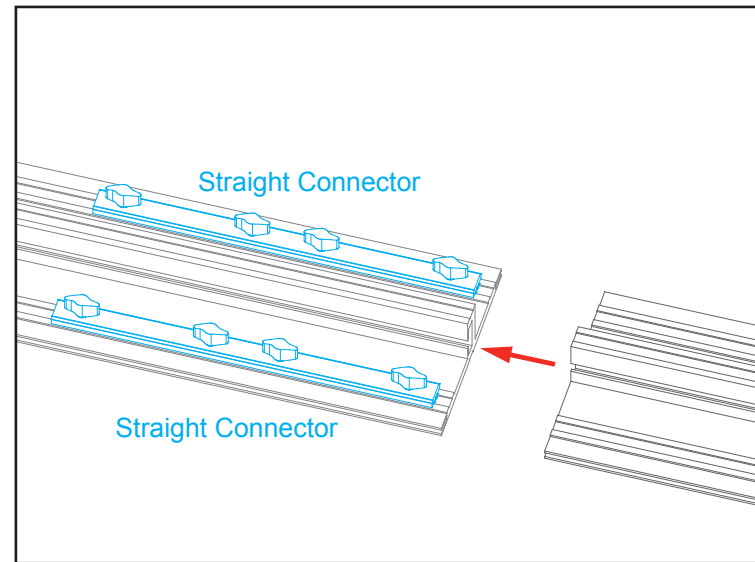

All knobs must be tightened securely to ensure a proper connection.

Disassembly

- 1) Loosen all knobs.
- 2) Slide connectors off of one extrusion.
- 3) Tighten knobs to prevent loss during packing & shipping.

Keep straight connectors in groove of extrusion. Do not remove connectors during disassembly.

Corner Connection

- 1) Loosen knobs, then slide vertical extrusions onto **corner connectors** of **lower** horizontal extrusion.
- 2) Slide **corner connectors** of **upper** horizontal extrusion into grooves of vertical extrusions.
- 3) Tighten all knobs to secure connection.

Disassembly

- 1) Loosen knobs on vertical extrusions.
- 2) Slide the vertical extrusions off of **corner connectors** on lower and upper horizontal extrusions.

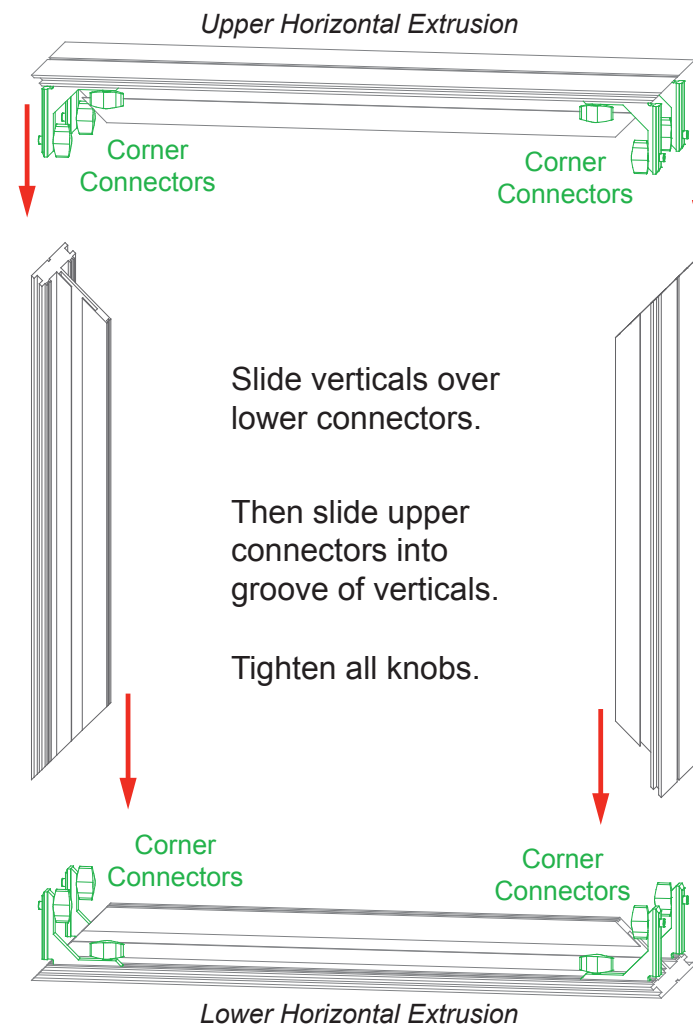

Slide verticals over lower connectors.

Then slide upper connectors into groove of verticals.

Tighten all knobs.

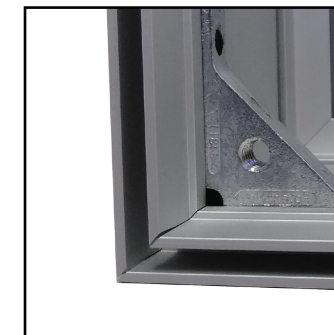

Adjust connectors if necessary to prevent gaps in connection.

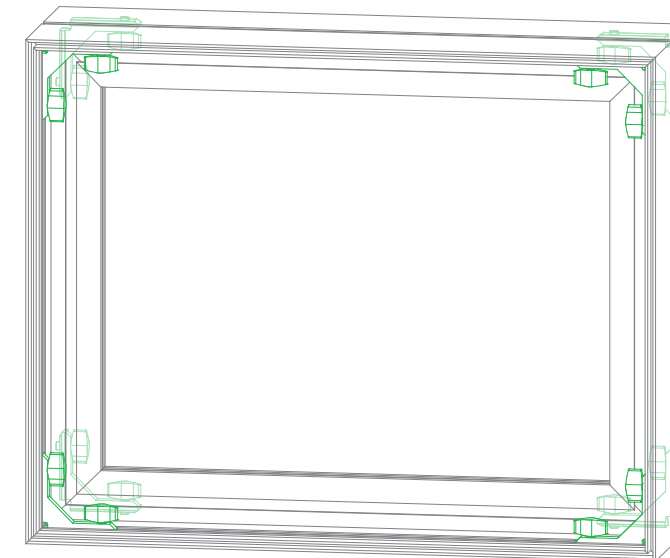

COMPLETED ASSEMBLY

All knobs must be tightened securely to ensure a proper connection.

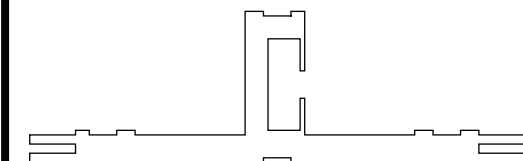

CEI152 Profile

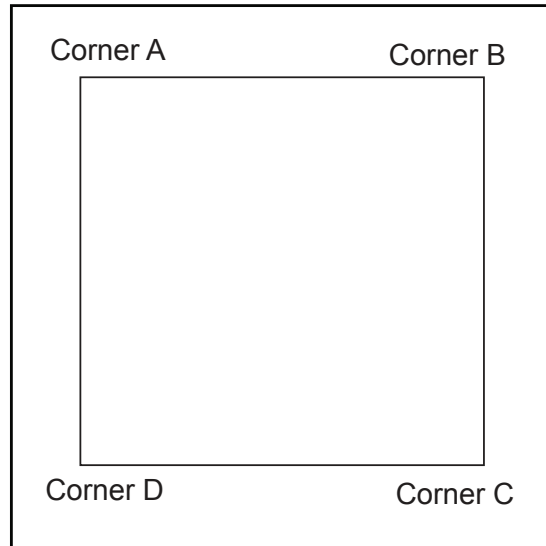

It is important to first insert graphic into each alternate corner then to the sides of the frame. If this is not done, graphic will not fit into the frame correctly.

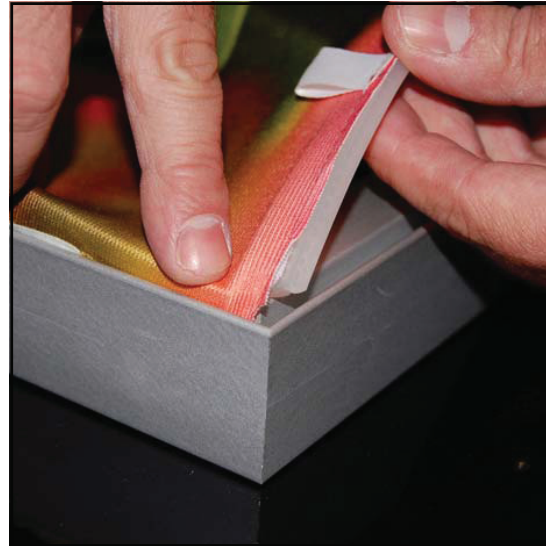

Step 1
Insert corner A. Turn edge of graphic so silicon welt is perpendicular to face of graphic. Insert narrow side of welt with fabric to outside into the channel. Repeat for other side of this corner.



Step 2
Repeat Step 1 for opposite corner C, then insert corner B, followed by corner D, to complete the installation of the corners.



Step 3
Once all corners are inserted, press one silicon edge into channel from corners and work toward the center. Make sure welt is fully inserted into channel. Continue until all sides are done. Smooth out edges of graphic.

Graphic Removal

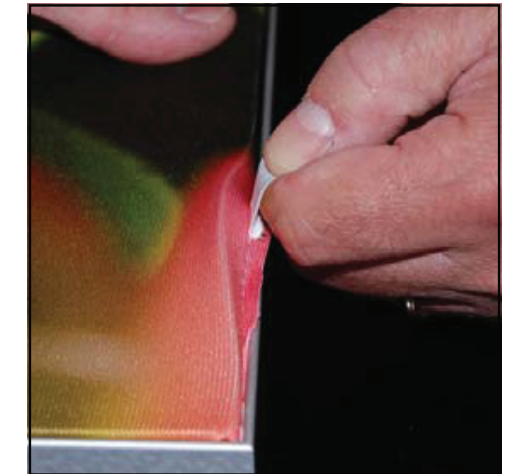

To remove the graphic from the frame, locate the fabric pull tab. Gently pull up on the tab to remove the fabric.

Top View of Each Level

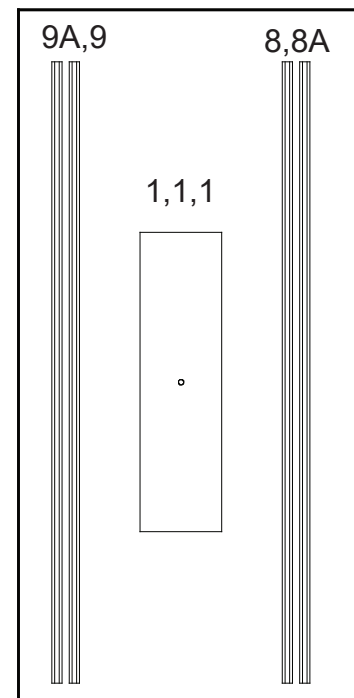

Level 1
(Bottom level)

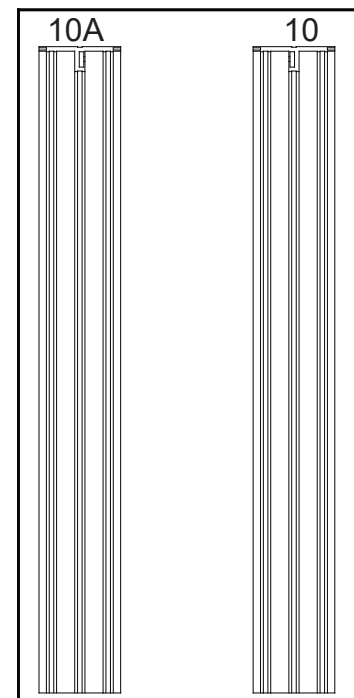

Level 2

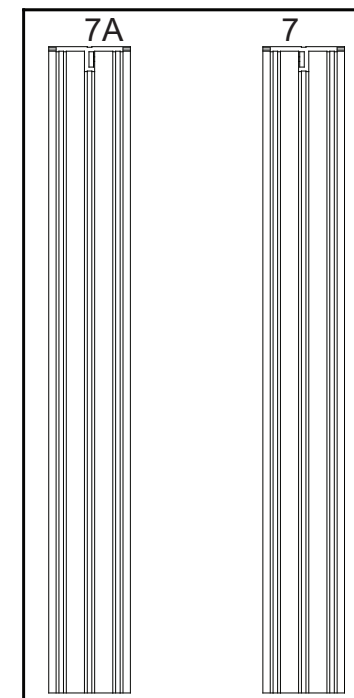

Level 3

Top View of Each Level

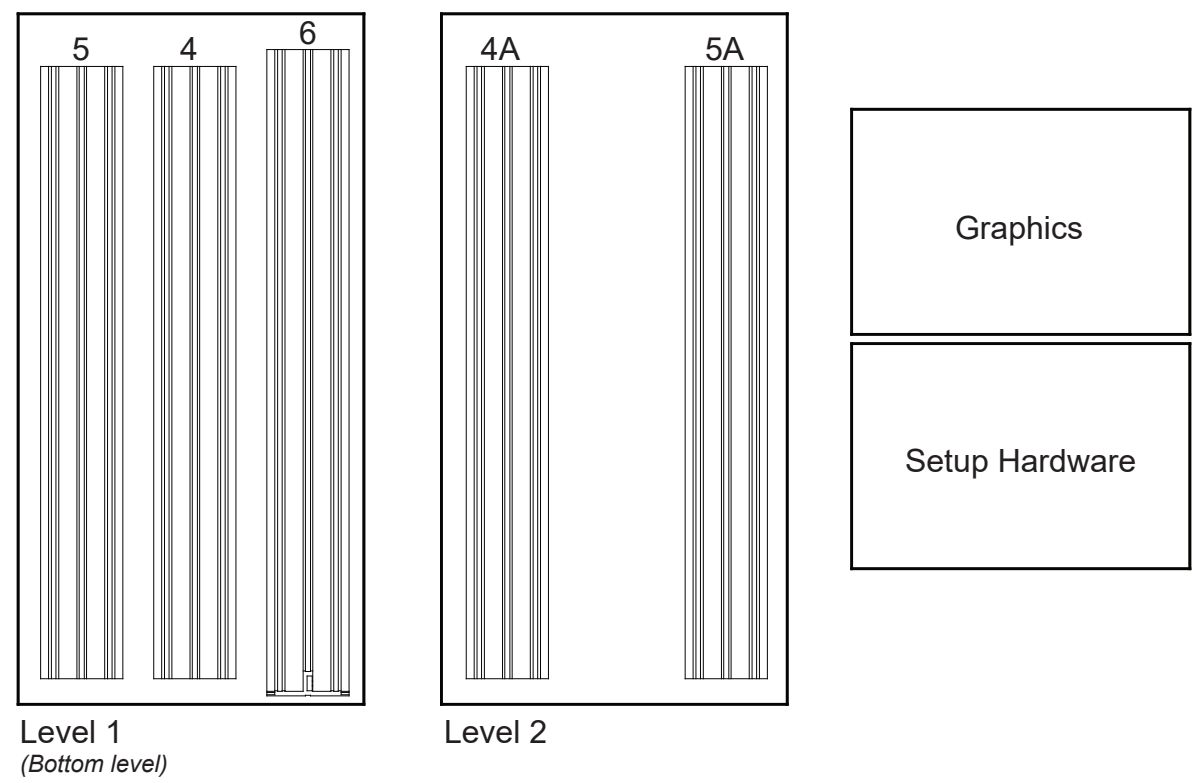

Top View of Each Level

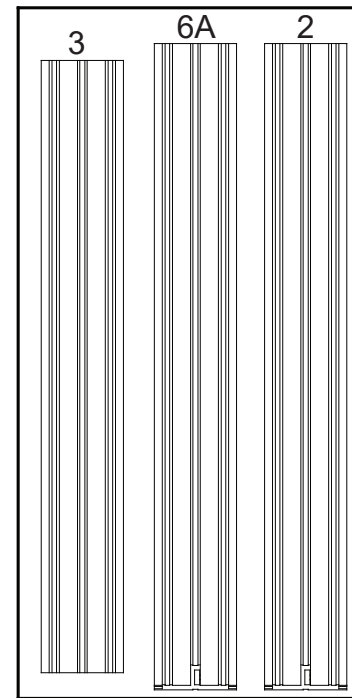

Level 1
(Bottom level)

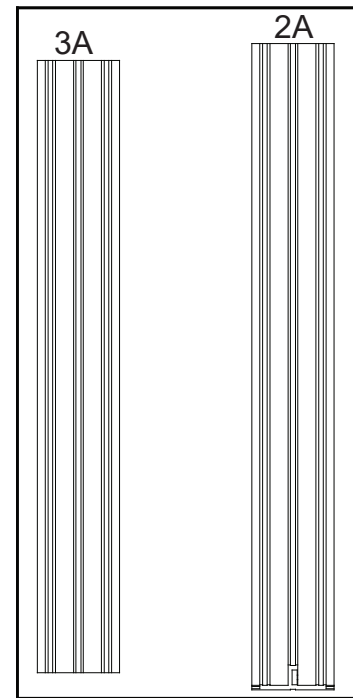

Level 2

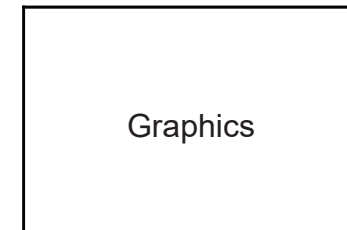

Item	Qty.	Description
1	3	Base Plate
2/2A	1/1	47.5" CEI152 Horizontal Extrusion
3/3A	1/1	45" CEI152 Horizontal Extrusion
4/4A	1/1	45" CEI152 Horizontal Extrusion
5/5A	1/1	45" CEI152 Horizontal Extrusion
6/6A	1/1	47.5" CEI152 Horizontal Extrusion
7/7A	1/1	47.5" CEI152 Vertical Extrusion
8/8A	1/1	45.677" Z33 Vertical Extrusion
9/9A	1/1	45.677" Z33 Vertical Extrusion
10/10A	1/1	47.5" CEI-152 Vertical Extrusion
--	2	U-Channel

Steps:

Refer to the CEI152 Frame Assembly general information page.

- 1) Attach U-Channels to horizontals [2,6]. See [U-Channel Attachment](#) detail.
- 2) Assemble horizontals [2-3-4-5-6], [2A-3A-4A-5A-6A] & verticals [7-7A], [8-8A], [9-9A], [10-10A] using straight connectors.
- 3) Connect vertical assemblies [7/7A], [10/10A] between horizontal assemblies [2/3/4/5/6], [2A/3A/4A/5A/6A] using corner connectors.
- 4) Attach verticals [8/8A], [9/9A] between horizontal assemblies.
See [Z45 Attachment](#) detail.
- 5) Connect Base Plates [1] to Horizontals [2,4,6], using bolts & wing nuts.

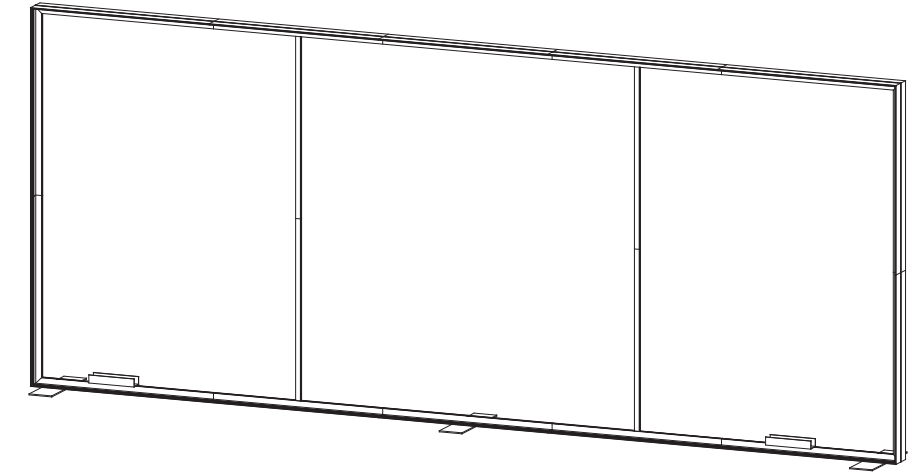

When assembled

Assemble frame flat on ground.

* Z45 Attachment

Attach Z45 vertical to *middle* groove of CEI-152 horizontal.

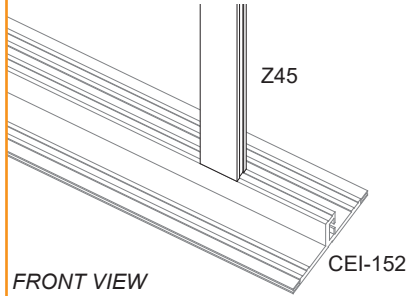

* U-Channel Attachment

Slide V4 connectors into top groove of horizontal extrusion. Tighten set-screws to secure.

Use bolts to connect U-Channel to horizontal.

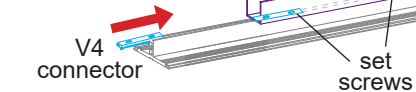

Keep U-Channels attached to extrusions when repacking.

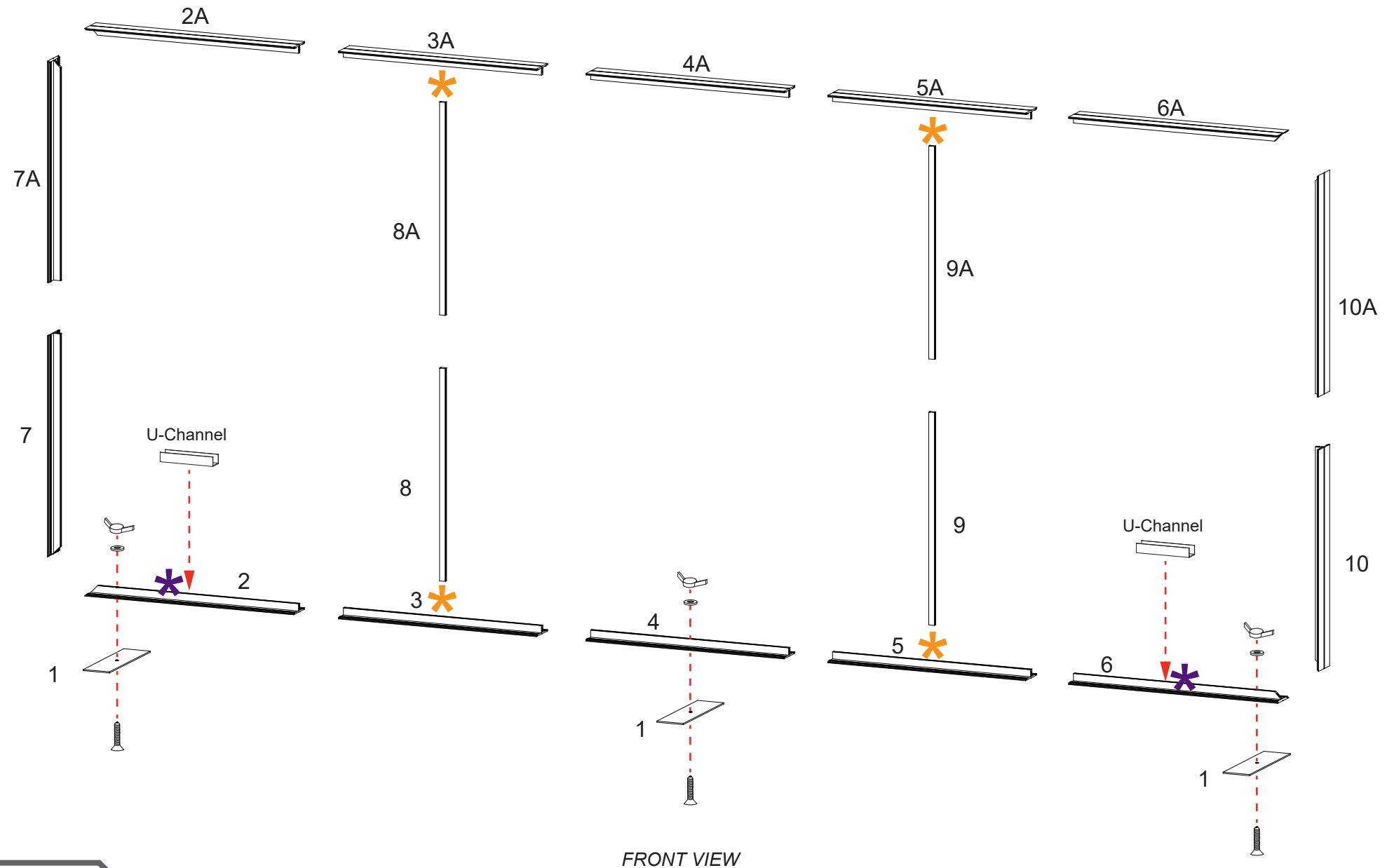

Steps:

- 1) Attach power cords to Supernova lights as shown.
- 2) Attach PR63 conduit to extrusions for wire management. See **PR63 Attachment** detail.
- 3) Apply SEG Graphics to assembled frame. Refer to the *SEG Installation general information page*.

PR63 Attachment

- 1) Run cords through PR63 plastic conduit.
- 2) Attach conduit by pinching the opening & inserting into the groove of extrusion.

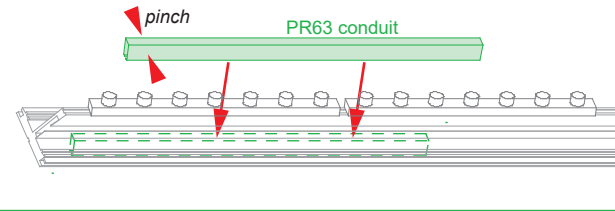

Light to Light Attachment

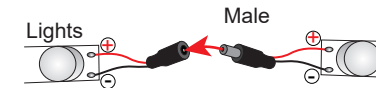

Light to Transformer Attachment

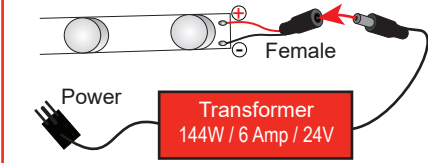

Maximum of 7 lights per chain / 11 lights per Transformer

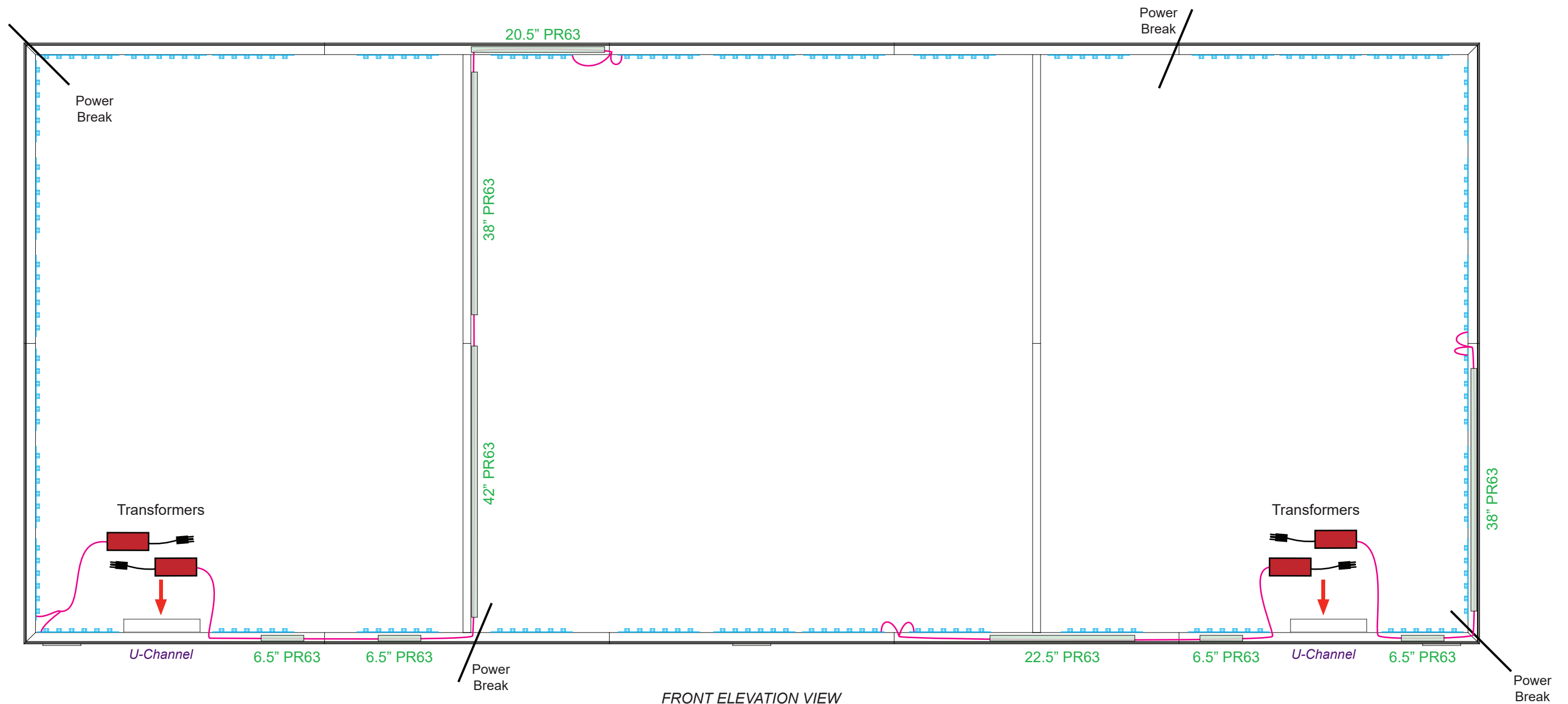

FRONT ELEVATION VIEW